

Installation Instructions

1. Surface Preparation

Ensure all surfaces to be coated are clean, free of dust, debris, and oil.

* It is important that the plasterboard wall and timber have been cleaned thoroughly.

If in doubt of the process, please refer to AS/NZS 2311:2017 Guide for Painting of Buildings.

2. Mastic Application

Fill any annular gap less than 5mm with GIB Fire Soundseal.

3. Intumescent Application

When GIB Fire Soundseal has dried, apply FBL-100 until the 650µm tooth of the WFT Comb provided has paint on it.

The patch on the wall is to be 100mm from each side of the timber.

Paint the top chord and bottom chord to 300mm from the wall.

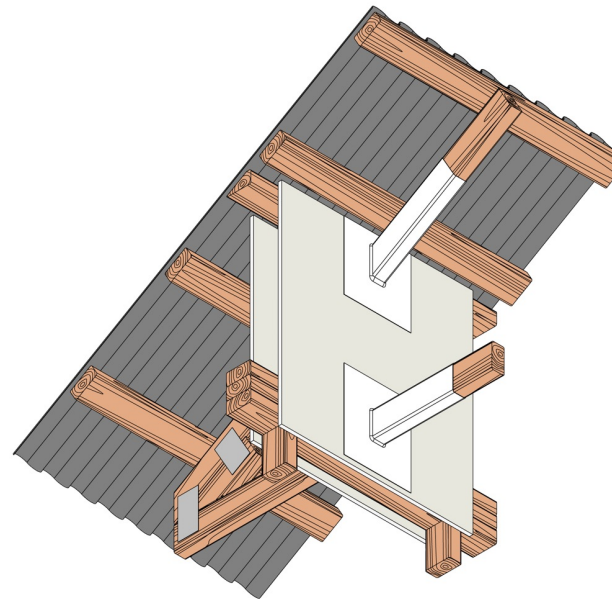

Notes:

This system may be used on any timber that penetrates, passes through or fills a gap in a fire rated wall. It does not matter if they are part of a truss (top chord, bottom chord or web) or a purlin, or a floor joist etc.

Nor does it matter if they have a combustible or non-combustible substrate, such as fibre cement sheet or plasterboard, or roofing material, on one or more of the timber profiles.

These drawings are for site example only. The performance of any fire rated system is dependent on, but not limited to the fire separating element, size of aperture, the cross-sectional size of penetration. Please refer to the Technical Data Specification for more detailed information or contact the Tech Coatings Technical department.

www.techcoatings.co.nz – technical@techcoatings.co.nz – +64 21 352 490

Tech Coatings Fire Rated Systems

System: PenoLock
TDS: PTR-NLT30-1
Approval: AS 1530.4:2014
Report #: PF22002
FRR: --/30/30

Fire Separating Element(s)

30/30/30 or --/30/30 fire rated wall

Penetration(s) Type

Timber Truss – Top Chord, Bottom Chord & Web

Size(s)

Timber with a cross sectional size greater than 90mm x 45mm, or denser than 350kg/m³

Materials

FBL-100, GIB Fire Soundseal

Please note:

Tech Coatings NZ Limited Ltd owns and has copyright on these drawings. They are to be used only for the purpose for which they were intended and supplied and are not to be sold, transferred, or made available for use by a third party. Any misuse of these drawings will result in legal proceedings.

Scale: NTS	Date: 07/09/2023
Sheet Size: A3	Prepared by: Shane Wyatt
TDS Number: PTR-NLT30	Version: 2.1

Installation Instructions

1. Surface Preparation

Ensure all surfaces to be coated are clean, free of dust, debris, and oil.

* It is important that the plasterboard wall and timber have been cleaned thoroughly.

If in doubt of the process, please refer to AS/NZS 2311:2017 Guide for Painting of Buildings.

2. Mastic Application

Fill any annular gap less than 5mm with GIB Fire Soundseal.

3. Intumescent Application

When GIB Fire Soundseal has dried, apply FBL-100 until the 650µm tooth of the WFT Comb provided has paint on it.

Paint the exposed part of the web.

The patch on the wall is to be 100mm from each side of the timber.

Paint the top chord and bottom chord to 300mm from the wall.

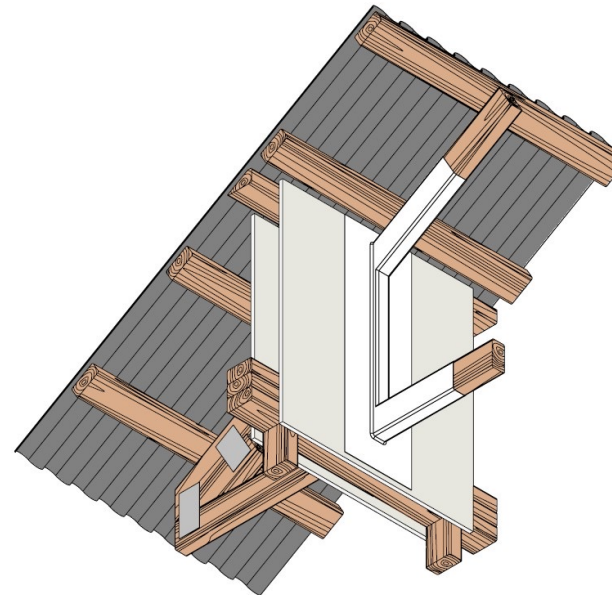

Notes:

This system may be used on any timber that penetrates, passes through or fills a gap in a fire rated wall. It does not matter if they are part of a truss (top chord, bottom chord or web) or a purlin, or a floor joist etc.

Nor does it matter if they have a combustible or non-combustible substrate, such as fibre cement sheet or plasterboard, or roofing material, on one or more of the timber profiles.

These drawings are for site example only. The performance of any fire rated system is dependent on, but not limited to the fire separating element, size of aperture, the cross-sectional size of penetration. Please refer to the Technical Data Specification for more detailed information or contact the Tech Coatings Technical department.

www.techcoatings.co.nz – technical@techcoatings.co.nz – +64 21 352 490

Tech Coatings Fire Rated Systems

System: PenoLock
TDS: PTR-NLT30-2
Approval: AS 1530.4:2014
Report #: PF22002
FRR: --/30/30

Fire Separating Element(s)

30/30/30 or --/30/30 fire rated wall

Penetration(s) Type

Timber Truss – Top Cord, Bottom Cord & Vertical Web

Size(s)

Timber with a cross sectional size greater than 90mm x 45mm, or denser than 350kg/m³

Materials

FBL-100, GIB Fire Soundseal

Please note:

Tech Coatings NZ Limited Ltd owns and has copyright on these drawings. They are to be used only for the purpose for which they were intended and supplied and are not to be sold, transferred, or made available for use by a third party. Any misuse of these drawings will result in legal proceedings.

Scale: NTS	Date: 07/09/2023
Sheet Size: A3	Prepared by: Shane Wyatt
TDS Number: PTR-NLT30	Version: 2.1

Installation Instructions

1. Surface Preparation

Ensure all surfaces to be coated are clean, free of dust, debris, and oil.

* It is important that the plasterboard wall and timber have been cleaned thoroughly.

If in doubt of the process, please refer to AS/NZS 2311:2017 Guide for Painting of Buildings.

2. Mastic Application

Fill any annular gap less than 5mm with GIB Fire Soundseal.

3. Intumescent Application

When GIB Fire Soundseal has dried, apply FBL-100 until the 650µm tooth of the WFT Comb provided has paint on it.

The patch on the wall is to be 100mm from each side of the timber.

Paint the timber purlin to 300mm from the wall, and paint a strip 100mm wide either side of the timber purlin on the substrate above.

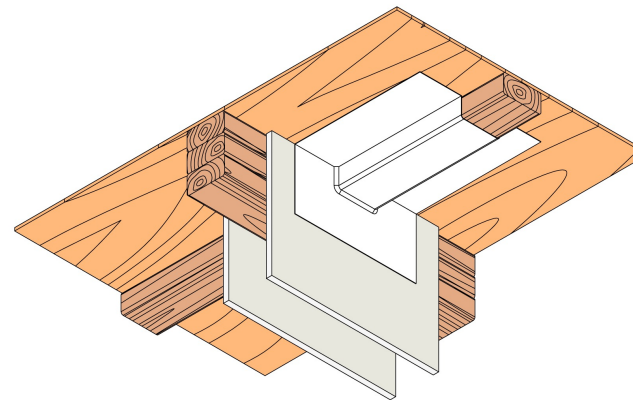

Notes:

This system may be used on any timber that penetrates, passes through or fills a gap in a fire rated wall. It does not matter if they are part of a truss (top chord, bottom chord or web) or a purlin, or a floor joist etc.

Nor does it matter if they have a combustible or non-combustible substrate, such as fibre cement sheet or plasterboard, or roofing material, on one or more of the timber profiles.

These drawings are for site example only. The performance of any fire rated system is dependent on, but not limited to the fire separating element, size of aperture, the cross-sectional size of penetration. Please refer to the Technical Data Specification for more detailed information or contact the Tech Coatings Technical department.

www.techcoatings.co.nz – technical@techcoatings.co.nz – +64 21 352 490

Tech Coatings Fire Rated Systems

System: PenoLock
TDS: PTR-NLT30-3
Approval: AS 1530.4:2014
Report #: PF22002
FRR: --/30/30

Fire Separating Element(s)

30/30/30 or --/30/30 fire rated wall

Penetration(s) Type

Timber Purlin with a combustible substrate covering one of the profiles of timber

Size(s)

Timber with a cross sectional size greater than 90mm x 45mm, or denser than 350kg/m³

Materials

FBL-100, GIB Fire Soundseal

Please note:

Tech Coatings NZ Limited Ltd owns and has copyright on these drawings. They are to be used only for the purpose for which they were intended and supplied and are not to be sold, transferred, or made available for use by a third party. Any misuse of these drawings will result in legal proceedings.

Scale: NTS	Date: 07/09/2023
Sheet Size: A3	Prepared by: Shane Wyatt
TDS Number: PTR-NLT30	Version: 2.1

Installation Instructions

1. Surface Preparation

Ensure all surfaces to be coated are clean, free of dust, debris, and oil.

* It is important that the plasterboard wall and timber have been cleaned thoroughly.

If in doubt of the process, please refer to AS/NZS 2311:2017 Guide for Painting of Buildings.

2. Mastic Application

Fill any annular gap less than 5mm with GIB Fire Soundseal.

3. Intumescent Application

When GIB Fire Soundseal has dried, apply FBL-100 until the 650µm tooth of the WFT Comb provided has paint on it.

The patch on the wall is to be 100mm from each side of the timber.

Paint the timber purlin to 300mm from the wall.

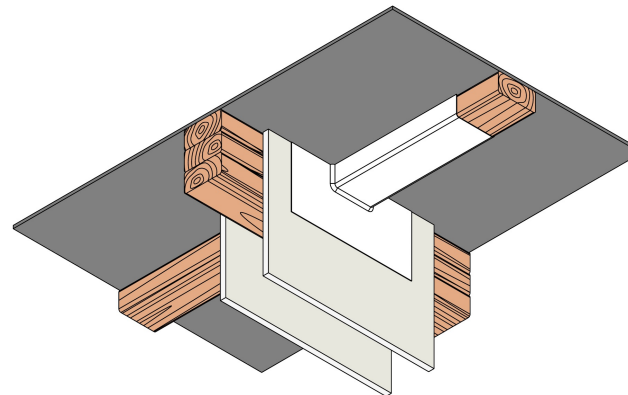

Notes:

This system may be used on any timber that penetrates, passes through or fills a gap in a fire rated wall. It does not matter if they are part of a truss (top chord, bottom chord or web) or a purlin, or a floor joist etc.

Nor does it matter if they have a combustible or non-combustible substrate, such as fibre cement sheet or plasterboard, or roofing material, on one or more of the timber profiles.

These drawings are for site example only. The performance of any fire rated system is dependent on, but not limited to the fire separating element, size of aperture, the cross-sectional size of penetration. Please refer to the Technical Data Specification for more detailed information or contact the Tech Coatings Technical department.

www.techcoatings.co.nz – technical@techcoatings.co.nz – +64 21 352 490

Tech Coatings Fire Rated Systems

System: PenoLock
TDS: PTR-NLT30-4
Approval: AS 1530.4:2014
Report #: PF22002
FRR: --/30/30

Fire Separating Element(s)

30/30/30 or --/30/30 fire rated wall

Penetration(s) Type

Timber Purlin with a non-combustible substrate covering one of the profiles of timber

Size(s)

Timber with a cross sectional size greater than 90mm x 45mm, or denser than 350kg/m³

Materials

FBL-100, GIB Fire Soundseal

Please note:

Tech Coatings NZ Limited Ltd owns and has copyright on these drawings. They are to be used only for the purpose for which they were intended and supplied and are not to be sold, transferred, or made available for use by a third party. Any misuse of these drawings will result in legal proceedings.

Scale: NTS	Date: 07/09/2023
Sheet Size: A3	Prepared by: Shane Wyatt
TDS Number: PTR-NLT30	Version: 2.1